

ABIDE BY ROHS

Linear Silent Shaft

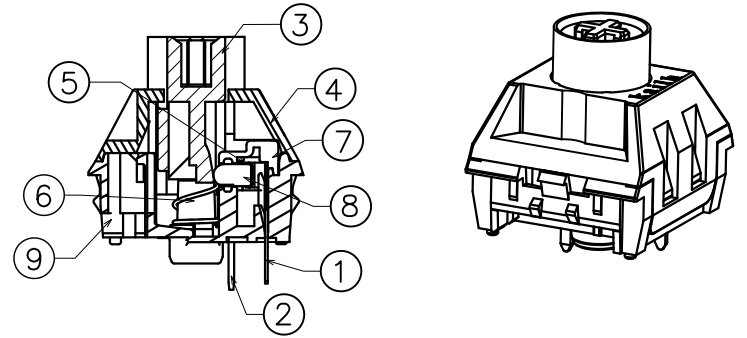
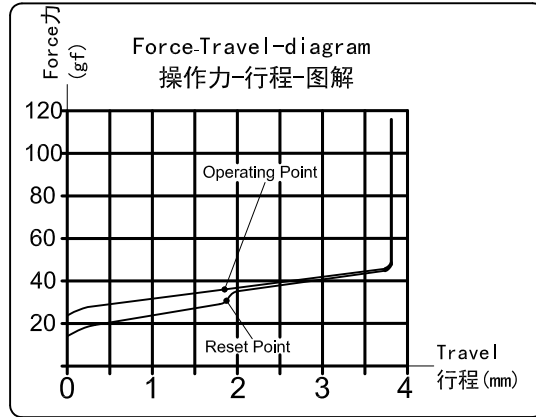
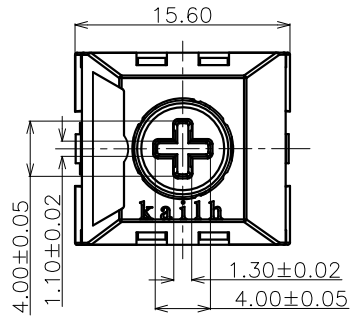

Specification :

- 1. Rating: 12 VAC/DC max. 2 VDC min. 10mA AC/DC max. 10 μA DC min.
 - 2. Contact Resistance: 200mΩ Max
 - 3. Insulation Resistance: 100MΩ Min. (DC100V)
 - 4. Withstand Voltage: AC100V(50-60Hz) for 1 minute
 - 5. Operation Force: 35±10gf
 - 6. Return Force: ≥15gf
 - 7. Conduction travel: 1.80±0.4mm
 - 8. Total travel: 3.60±0.4mm
 - 9. Electrical Life: 80,000,000 Cycles(min).
 - 10. Degree of protection: IP56(excluding the terminals, samples should be applied to products that meet the corresponding protection level)
- <Feel is allowed to have difference before and after life test>

SWITCH FUNCTION

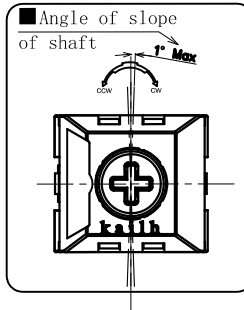
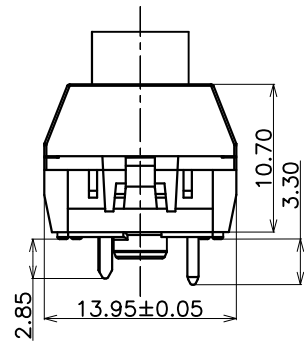
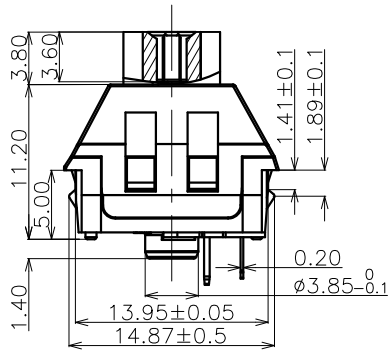
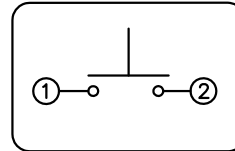

B

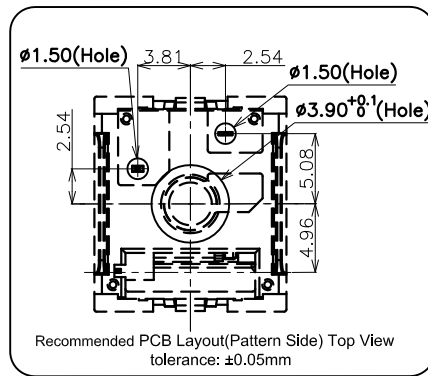
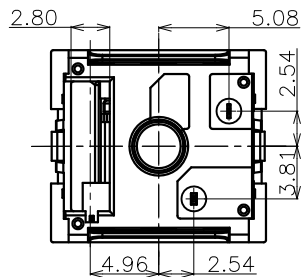

A

⑨	Base	1	PA66	White		
⑧	Slider	1	POM	Green		
⑦	Protecting Cover	1	PA66	Nature		
⑥	Spring	1	Stainless Steel	Nature		
⑤	Contact	2	Composite gold			
④	Cover	1	PC	Nature		
③	Keystroke	1	POM/TPE	Pink		
②	Static Plate	1	Copper Alloy	Nature		
①	Movable Plate	1	Copper Alloy	Nature		
ITEM	PART NAME	TER'NO	QTY.	MATERIAL	FINISHING	REMARK

APPROVALS		DATE	DONGGUAN CITY KAIHUA ELECTRONICS CO.,LTD Kailh		
DRAWN	L.Zhang	2019.12.17	TITLE:	PG1511F Linear Silent Keystroke Switch	
CHECKED			PART NO.	CPG1511F01S37	
APPROVALS			UNIT: mm	SCALE: 1:1	PROJ:
TOLERANCES ARE			ANGLE	DRAWING NO.	SHEET 1 OF 1
30<L	±0.30	±2°	UNIT: mm	SCALE: 1:1	PROJ:
10<L	±0.20				
5<L	±0.15				
L	±0.10				

ECN NO.	REV.	DATE.	NEW DESCRIPTION.	L.Zhang	CHANGE.	CHECK.	APPRO.
	A	2020.03.19					

4

3

2

1



凱華電子
KAIHUA EEELETRONICS

Document Number:

KH-PS1912-19

产品规格书

Product Specification

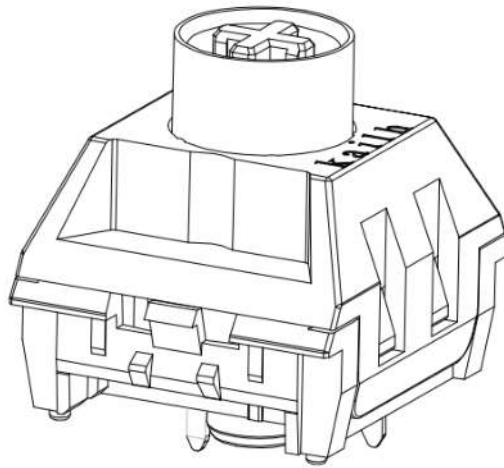

Linear Silent Shaft
(线性静音轴 35gf)

P/N: CPG1511F01S37			Title : PG1511F Keyboard Switch		
Rev.	ECN	Release and Revision Description:	Prepared By /Date:	Checked By/Date:	Approved By/Date:
A	— —	New releasing 初版发行	张林/2019.12.17	张林/2020.03.20	吕攀豪/2020.03.20



P/N: CPG1511F01S37	DOC. No.: KH-PS1912-19	Rev.: A	Page: 2/11
-----------------------	---------------------------	------------	---------------

Content

目录

1. Scope/范围:	3
2. Product Application/产品应用 :	3
3. Technology Parameters/技术参数	3
4. Ratings/额定性能要求.....	3
5. Profile Dimensions /外形尺寸	3
6. Electrical Performance/电气性能	4
7. Mechanical Performance/机械性能.....	5~7
8. Environmental Performance/环境性能.....	7~9
9. Recommended PCB Layout/推荐的 PCB 安装焊盘规格.....	9~10
10. Loading Parameter Specification/荷重参数规格	10
11. Packaging/包装	10~11
12. Precaution/注意事项.....	11



P/N: CPG1511F01S37	DOC. No.: KH-PS1912-19	Rev.: A	Page: 3/11
------------------------------	----------------------------------	-------------------	----------------------

1. Scope/范围:

This Product Specification covers the requirement of Mechanical Keyboard switch on product performance, test methods and quality assurance provisions.

本规格书内容涵盖机械键盘开关产品的要求，包括性能指标、测试方法及质量保证方面等。

2. Product Application/产品应用:

Mainly applied on computer keyboards, cash registers, industrial equipment and Man-Machine interface.

主要适用于电脑键盘，收银机、工业设备和人机界面。

3. Technology Parameters/技术参数

Ambient Humidity 工作湿度:	45~85% R.H.;
Operating Temperature Range 使用温度范围:	-10℃~+70℃;
Storage Temperature Range 保存温度范围:	-20℃~+70℃;
Suggested storage period 贮存期限:	about 6 months 最多 6 个月
Require the tin part on the switch terminals should keep good after storage guarantee date 要求贮存期后开关端子部分上锡仍然良好。	
Normal Condition:	
Ambient temperature 环境温度:	20±2℃
Relative humidity 相对湿度:	65%±5% R.H.;
Air pressure 气压:	86~101KPa;

4. Ratings/额定性能要求

Rating 额定负荷:	12V AC/DC max. 2V DC min. 10mA AC/DC max. 10 μ A DC min.;
Insulation Resistance 绝缘电阻:	≥100MΩ/DC 100V;
Withstand Voltage 耐电压:	100 AC 1 Minute;
Mechanical Life 机械寿命:	80,000,000 Cycles.

5. Profile Dimensions /外形尺寸

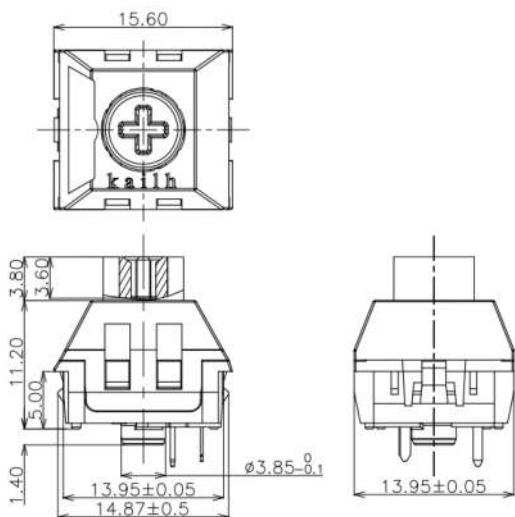

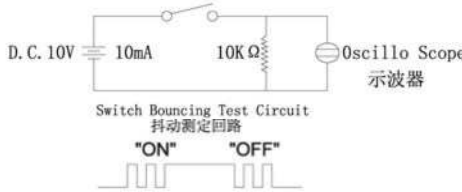

6. Electrical Performance/电气性能

Item 项目	Description 项目描述	Test Condition 测试条件	Requirement 规格要求
6.1	Contact Resistance 接触电阻	<p>Static load: (Operation force)x2, which is applied on the center of Switch stem. Be measured when the switch contact stabilization. 静态负载: 动作力的 2 倍, 施加在手柄中心. 开关接触稳定时量测.</p> <p>Measurement tool: Contact resistance Meter. 测量工具: 微电流接触电阻计(1KHz, 20mV, 5~50mA)</p> <p>Measured at low current (100mA or less). 在低电流 (≤100mA) 条件下测试.</p>	<p>200mΩ Max 200mΩ以下</p>
6.2	Insulation Resistance 绝缘电阻	<p>Apply a Voltage of DC 100 V for 1 minute, according to the below method. (1) Between terminals. (2) Between terminal and Body.</p> <p>输入 100V DC 电压 1 分钟, 按如下接触方法测试: (1) 端子与端子之间. (2) 端子与外壳之间.</p>	<p>100MΩ Min 100 兆欧以上</p>
6.3	Dielectric withstanding voltage 耐电压	<p>Apply a Voltage of AC100 V (50~60Hz) for 1 minute, according to the below method. (1) Between terminals. (2) Between terminal and Body.</p> <p>输入 100V AC 电压 1 分钟, 按如下接触方法测试: (1) 端子与端子之间. (2) 端子与外壳之间.</p>	<p>No evidence of breakdown 无瞬断、击穿等破坏.</p>
6.4	Bouncing 触点抖动	<p>Operation speed: 3~4 times/s 操作速度: 每秒 3~4 次</p> <p>Oscillo scope 示波器</p> <p>Switch Bouncing Test Circuit 抖动测定回路.</p> 	<p>Before Life cycle: On: 5ms MAX, 5 毫秒以下 Off: 5ms MAX, 5 毫秒以下</p> <p>After Life cycle: On: 10ms MAX, 10 毫秒以下 Off: 10ms MAX, 10 毫秒以下</p>

7. Mechanical Performance/机械性能

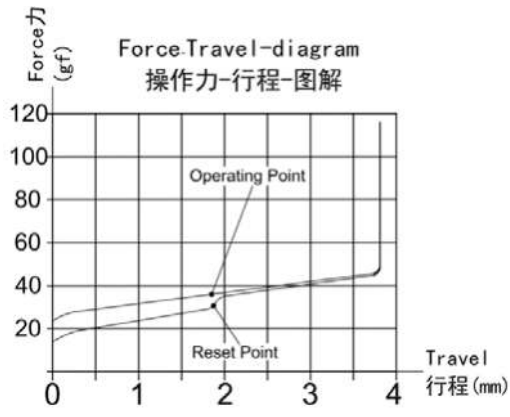
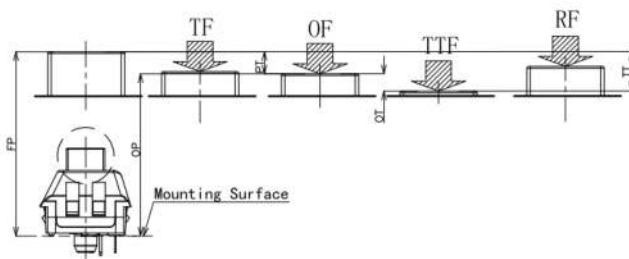
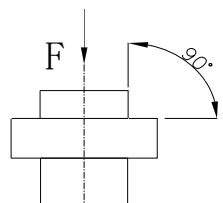
Item 项目	Description 项目描述	Test Condition 测试条件	Requirement 规格要求
7.1	Load Curve 荷重曲线	<p>Place the vertical direction of switch operation and gradually increase the load applied to the center of the stem until it stop. 开关的动作方向为垂直放置，向手柄中心逐渐施加负荷直到停止。</p>  <p>The diagram is a line graph titled 'Force-Travel-diagram' and '操作力-行程-图解'. The y-axis is labeled 'Force力 (gf)' and ranges from 0 to 120 in increments of 20. The x-axis is labeled 'Travel 行程 (mm)' and ranges from 0 to 4 in increments of 1. The graph shows a curve that starts at approximately (0, 20), rises to about (1, 30), then more steeply to (2, 40), and finally levels off towards (4, 50). A point on the curve at approximately (2, 35) is labeled 'Reset Point', and a point at approximately (2.5, 80) is labeled 'Operating Point'.</p>	See page 11 见第 11 页
7.2	Loading parameter 荷重参数	<p>Place the vertical direction of switch operation and gradually increase the load applied to the center of the stem until it stop. 开关的动作方向为垂直放置，向手柄中心逐渐施加负荷直到停止。</p>  <p>The diagram shows a cross-sectional view of a switch mechanism. Four loading points are indicated with arrows and labels: TF (Top Force) at the top of the stem, OF (Offset Force) at the top of the stem offset from the center, TTF (Top Tip Force) at the tip of the stem, and RF (Right Force) at the right side of the stem. A 'Mounting Surface' is also labeled at the bottom of the stem. Dimensions like 'H' and 'b' are also shown.</p>	See page 11 见第 11 页
7.3	Static Strength 静止强度	<p>A static load of 3kgf shall be applied in the direction of button operation for a period of 60 seconds. 在手柄动作方向施加 3kgf 的静负荷 60 秒，然后测试参数。</p>  <p>The diagram shows a simple rectangular stem with a downward force vector 'F' and a curved arrow indicating a 90-degree angle to the stem's vertical axis.</p>	No damage (Electrical) And mechanical) 电气和机械性能正常。

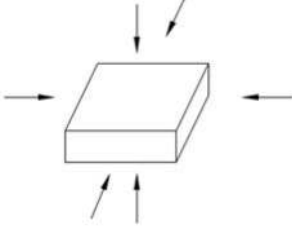

7.4	Stem Pull Strength 手柄拉拔强度	Break by a pull force applied opposite to the direction of stem operation. 在推柄动作方向反向垂直施加拉力，使其破坏的程度。	5kgf Min
7.5	Shock 机械冲击	Measured by according to the below condition: (1) Acceleration: 80g 加速度 (2) Cycles of test:3 cycles each in 6 directions, for a total of 18 cycles. 试验次数：每个方向 3 次，6 个方向共 18 次。 	Shall meet No.6, 7.1, 7.2. 满足 6, 7.1, 7.2 要求。
7.6	Life Test 寿命测试	1) D.C.12V 10mA resistance load D.C 12V 10mA 电阻负荷 2) Operation speed: 5-6 times / s 动作速度: 5-6 次/ 秒 3) Push force: 150gf 按力: 150gf 5) Push travel: 3.6mm 按压行程: 3.6mm 6) Operation number: 80,000,000cycles 动作次数: 80,000,000 次	Contact resistance: 1Ω Max 接触电阻: 1 欧以下 Bouncing: 10ms Max 触点抖动: 10 毫秒以下 Operation force: Variation rate within ±30% 操作力的变化范围在初始值的±30%以内。
7.7	Noise Test 噪音测试	1、Decibel meter model : BK2250-L 分贝仪型号: BK2250-L 2、background noise: 10 dB Max 背景噪音: 10 dB Max 3、Metal strip to click product 3 times per second for 10 seconds, to maximize the noise test results by dB 金属头按击产品每秒 3 次持续 10 秒，测试结果取噪音最大值 dB	40 分贝 MAX

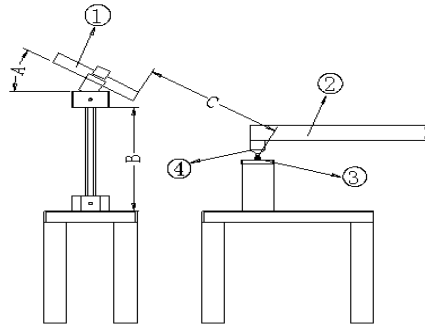

A=麦克风角度: 30°
B=麦克风摆放高度: 135mm
C=麦克风与产品距离: 150mm

①: 麦克风
②: 按压传动杆
③: 测试产品
④: 金属按压头

8. Environmental Performance/环境性能

Item 项目	Description 项目描述	Test Condition 测试条件	Requirement 规格要求												
8.1	Cold test 耐寒性	(1) Temperature : - 20±2℃ 温度: - 20±2℃ (2) Duration of test: 48h 持续时间: 48 小时 (3) Take off a drop water 去掉水珠 (4) Standard conditions after test : 1h 试验后的放置条件: 1 小时	Contact resistance: 200mΩ Max Shall meet : No. 6.2 to 6.4 No. 7.1 to 7.2 接触电阻 200mΩ 以下 满足: No. 6.2 to 6.4 No. 7.1 to 7.2												
8.2	Heat test 耐热性	(1) Temperature : 70±2℃ 温度: 70±2℃ (2) Duration of test: 48h 持续时间: 48 小时 (3) Take off a drop water 去掉水珠 (4) Standard conditions after test : 1h 试验后的放置条件: 1 小时	Contact resistance: 200mΩ Max Shall meet : No. 6.2 to 6.4 No. 7.1 to 7.2 接触电阻 200mΩ 以下 满足: No. 6.2 to 6.4 No. 7.1 to 7.2												
8.3	Temperature cycle 温度循环	(1) Test cycles: 5 cycles 试验周期: 5 个周期 (2) Standard condition after test:1h 试验后的放置条件: 1 小时 <table border="1" style="margin-left: 20px;"> <thead> <tr> <th></th> <th>Temperature 温度</th> <th>Duration of test 持续时间</th> </tr> </thead> <tbody> <tr> <td rowspan="4">1 cycle 一次循环</td> <td>20±5℃</td> <td>1h</td> </tr> <tr> <td>-20±5℃</td> <td>1h</td> </tr> <tr> <td>20±5℃</td> <td>1h</td> </tr> <tr> <td>70±5℃</td> <td>1h</td> </tr> </tbody> </table>		Temperature 温度	Duration of test 持续时间	1 cycle 一次循环	20±5℃	1h	-20±5℃	1h	20±5℃	1h	70±5℃	1h	Contact resistance: 200mΩ Max Shall meet : No. 6.2 to 6.4 No. 7.1 to 7.2 接触电阻 200mΩ 以下 满足: No. 6.2 to 6.4 No. 7.1 to 7.2
	Temperature 温度	Duration of test 持续时间													
1 cycle 一次循环	20±5℃	1h													
	-20±5℃	1h													
	20±5℃	1h													
	70±5℃	1h													

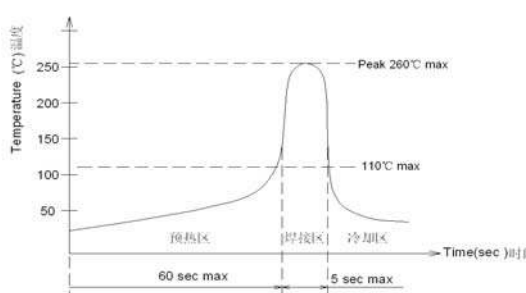

8.4	Soldering heat test 耐焊接热	<p>Soldering area: T/2 of PWB thickness. (PWB: T=1.6mm) 焊接面积: 印刷基板的 1/2 厚度处</p> <p>Soldering temperature: 260±5°C 焊接温度: 260±5°C</p> <p>Soldering time: 3±0.5s 焊接时间: 3±0.5 秒</p>	Appearance: No abnormality. 外观无异常
8.5	Solder ability 可焊性	<p>1. Hand soldering 手工焊接: Please practice according to below condition: (1) Soldering Temperature : 350±5°C 焊接温度: 350±5°C (2) Continual soldering time: 3±0.5s 连续焊接时间: 3±0.5 秒 (1) Capacity of soldering iron: ≤20w 电烙铁功率: 20 瓦以下</p> <p>2. Automatic PIP soldering 自动插板焊接: For the product of T/H according to below condition: 波峰焊温度曲线图(单波峰)</p>  <p>The graph shows Temperature (°C) on the y-axis (0 to 250) and Time(sec) on the x-axis. The curve rises to a peak of 260°C max, then falls to 110°C max. The pre-heat zone (预热区) is marked as 60 sec max, and the cooling zone (冷区) is marked as 5 sec max.</p>	At least 95% of surface area of immersed portion shall be covered by solder. 浸焊面积大于 90%以上.
8.6	Humidity test 耐湿性	<p>(1) Temperature : 60±2°C 温度: 60±2°C</p> <p>(2) relative humidity: 90~95% R.H. 相对湿度:90~95% R.H.</p> <p>(3) Duration of test: 48h 持续时间: 48 小时</p> <p>(4) Take off a drop water 去掉水珠</p> <p>(5) Standard conditions after test: 1h 试验后的放置条件: 1 小时</p>	Contact resistance: 200mΩ Max Shall meet : No. 6.2 to 6.4 No. 7.1 to 7.2 接触电阻 200mΩ 以下 满足: No. 6.2 to 6.4 No. 7.1 to 7.2



P/N: CPG1511F01S37	DOC. No.: KH-PS1912-19	Rev.: A	Page: 9/11
------------------------------	----------------------------------	-------------------	----------------------

8.7	Salt Spray 盐雾测试	<p>Apply the following environment to test(Only for contact test) :</p> <p>根据下列条件进行测试(仅针对触点测试):</p> <p>(1) Temperature : 35±5°C 温度: 35±5°C;</p> <p>(2) Salt water density: 5±1% 盐水浓度: 5±1%;</p> <p>(3) Duration: 12hours 持续时间: 12 小时;</p> <p>(4) After test, the salt deposit shall be removed by running water. 实验后将盐沉积物用水冲掉</p>	<p>Appearance: No corrosion spot, no crack, no base plate naked. 外观: 无腐蚀点,无裂纹,无裸露基材.</p> <p>Contact Resistance: 200 mΩ Max 接触电阻: 200 毫欧以下</p>
8.8	Protection Against ingress of dust(IP5X) 防尘	<p>The switches are placed in a position of normal use inside the test chamber. The test is carried out according to the second enclosure of IEC60529/GB4208. The test shall be continued for a period of 8h.</p> <p>测试样品以正常使用位置在防尘箱中安装 ; 按 IEC60529 或 GB4208 防护标准测试条件进行试验 ; 试验应持续 8 小时 ;</p>	<p>After test: Operating is normal Between terminals, terminal and surface of the crust, Dielectric withstand in voltage ≥100V</p> <p>动作正常; 端子之间及端子与外壳表面耐电压强度≥100V</p>
8.9	Protection against ingress of water(IPX6) 防水	<p>The switches are placed in a position of normal use inside the test table. The test is carried out according to the second enclosure of IEC60529/GB4208.</p> <p>测试样品以正常使用位置在防尘箱中安装 ; 按 IEC60529 或 GB4208 防护标准测试条件进行试验 ;</p>	<p>After test: Operating is normal. Water don't enter electric parts of the switch inside. Between terminals, terminal and surface of the crust, Dielectric withstand in voltage ≥100V</p> <p>动作正常; 水不能进入开关内带电部份 端子之间及端子与外壳表面耐电压强度≥100V</p>

9. Recommended PCB Layout 推荐的 PCB 安装焊盘规格

Mounting Options 安装选项

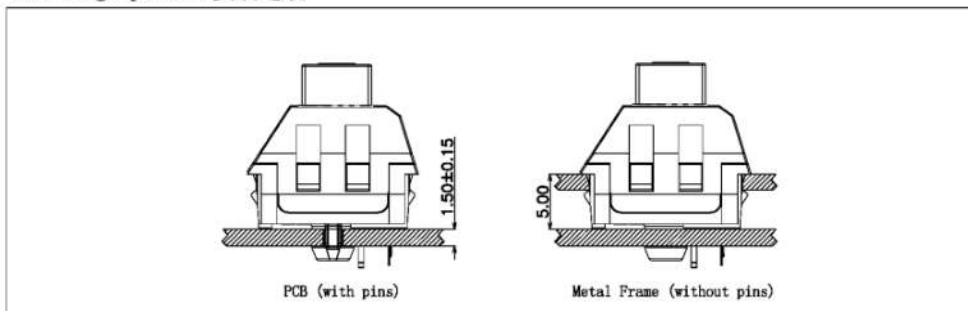

Circuit Board Layouts 电路板布局

Grid line spacing = 1.27mm 网格线间距= 1.27毫米

Keyswitch without fixation pins
按键开关不带定位柱



Keyswitch with fixation pins
按键开关带定位柱



Metal Frame Cutout Dimensions

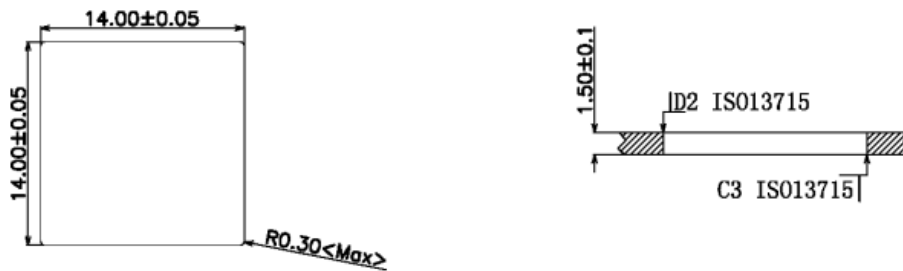

10. Loading Parameter (TT/PT/OT /OF/TF/RF) Specification 荷重参数规格 :

Parameter	Unit	Specification	Remark
TT(总行程)	mm	3.60±0.3	
PT(导通行程)	mm	1.80±0.4	
OT(过行程)	mm	1.30	Min.
OF(动作力)	gf	35±10	
RF(回弹力)	gf	15	Min.

11. Packaging 包装

Packaging type: Tray, 1000Pcs/Tray, 4000Pcs/Carton.

包装方式: Tray 盘,1000Pcs/盘, 4000Pcs/箱.

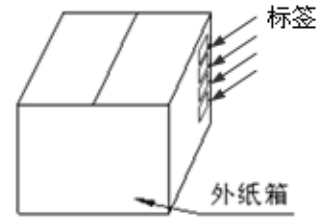
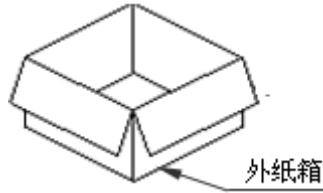

12. Precaution 注意事项

12.1 Immersion Soldering condition 浸焊条件

ITEM 项目	CONDITION 条件
Preheat temperature 预热温度	110°C Max (Ambient temperature of soldering surface of P.W.B) 110°C 以下(印刷基板焊锡面周围的温度)
Preheat time 预热时间	60s, Max 60 秒以内
Area of flux 助焊剂面积	1/2 Max of PWB Thickness 印刷基板厚度的 1/2 以内
Temperature of solder 焊锡温度	260±5°C 260±5°C
Time of immersion 浸焊时间	3s±0.5s 3s±0.5s
Number of soldering 焊接次数	2time Max (But should down heat of the first soldering) 2 次以内
Printed wiring board 印刷基板	Single side copper-clad laminates 单面铜箔

- (1) After switches were soldered, please be careful not to clean switches with solvent
开关浸焊后,注意不要用溶剂清洗.
- (2) Under the condition of using soldering iron, soldering temperature shall be 350°C±5°C with 3±0.5s.
在使用烙铁的情况下,焊锡温度应在350°C±5°C,焊接时间3±0.5秒.

12.2 Notes 注意点

- (1) Please be cautious not to give excessive static load or shock to switches.
注意不要施加超负荷的压力或晃动开关.
- (2) Please be careful not to stack up P. W. B. after switches were soldered.
开关焊接以后,印刷基板注意不要叠放.
- (3) Preservation under high temperature and high humidity or corrosive gas should be avoided
Especially. When you need to preserve for a long period, do not open the carton.
保管时尤其应注意避开高湿高温和有腐蚀性气体的环境.如需长时间保存,请不要打开包装箱.
- (4) Products meet the ROHS & REACH environmental management substances control standards
产品满足 ROHS & REACH 环境管理物质管制标准